

Application area

- For medium and larger presses
- For clamping upper, lower and interior dies on multi-acting presses
- For dies and adapter plates with identical dimensions and integrated lockplates or U-recesses
- Stationary installation on the edge of slide, the slide or the machine bed

Mode of operation

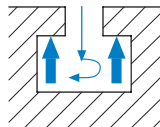
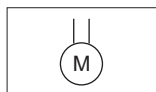

- An electric motor with gear provides the extension and retraction movement and the clamping force.
- During the clamping and unclamping movement the tie rod is turned through 90°.

Description

By means of a gear drive an electric motor causes a spindle to rotate. Through this a nut and the tie rod connected to it is moved up or down.

Before the end of its extension movement the tie rod is mechanically unlocked and turned. Energy is only required during the clamping and unclamping processes. The clamp unit is mechanically self-locking. The clamping force is continuously monitored.



Advantages

- Mechanically self-locking
- Electric monitoring of all functions
- Fully automated operation
- Large clamping dimension tolerance
- Continuous clamping force monitoring

Accessories

- Limit switches/cables
- Plug connectors

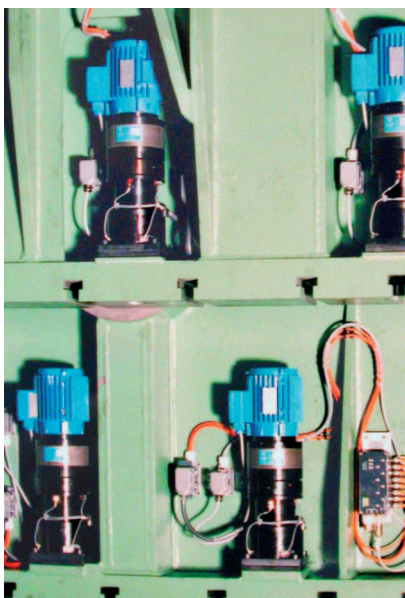

Technical Data

Type	EDH 60	EDH 120	EDH 240
Clamping force [kN]	60	120	240
Max. loading force [kN] ¹⁾	100	200	400
Clamping dimension tolerance [mm]	+/- 7		
Stroke [mm]	92	107	137
Clamping speed [mm/s]	3		
Motor: Art Supply voltage[V]	three-phase 400		
Motor power [kW]	0.55	0.75	1.5
Limit switches: Number / Type Supply voltage Connection type Designation	<ul style="list-style-type: none"> • Four inductive proximity switches • PNP normally open ; 10-30 V DC • Plug-in type (M8x1) • Tie rod retracted S3 • Tie rod in clamping position S5 • Continuous clamping force monitoring S6 • Tie rod in unclamping position S7 		
Max. operating temperature [°C]	70		
Weight [Kg]	36	40	50

¹⁾ Mechanical damage may occur at higher loads.

Fixing is achieved with four screws M12, DIN 912 strength class 8.8 (not included).

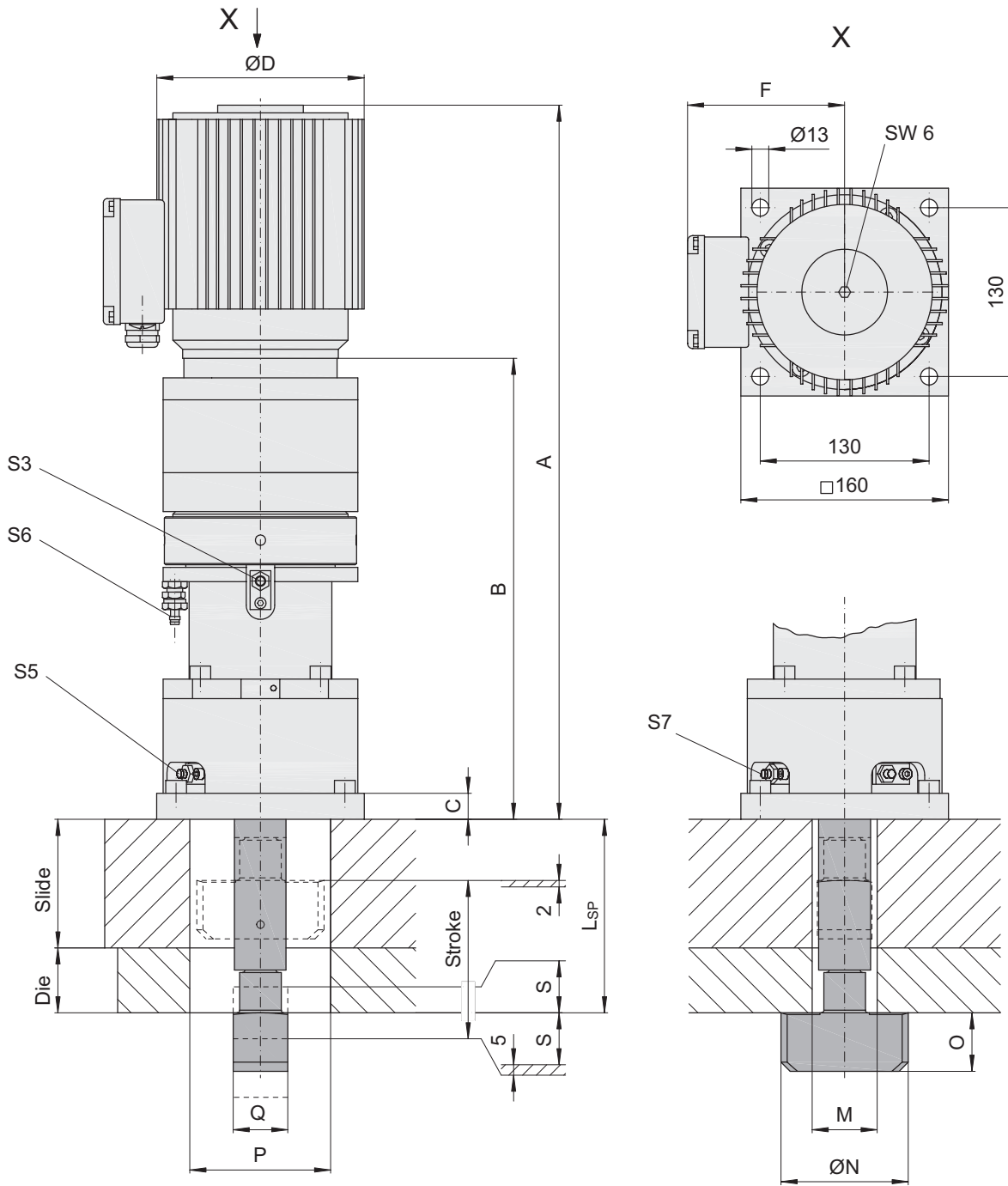

Technical specifications are subject to change without notice!

(Custom designs available on request)

L_{SP} = Nominal clamping dimension [mm]

Type	stroke	S	A	B	C	ØD	F	M		ØN	O	P	Q	L _{SP} min.
								min.	max.					
EDH 60	92	7	510	330	20	150	102	45	50	80	30	90	36	95
EDH 120	107	7	548	353	20	160	123	50	60	98	45	120	42	110
EDH 240	137	7	624	429	30	160	123	65	70	120	60	160	62	140

Example order

EDH 120 - 150
 Type _____
 L_{SP} _____