

Application area

- For medium and large presses
- For various die dimensions
- For clamping upper dies
- For dies with U-recesses
- Suitable for retrofitting

Mode of operation

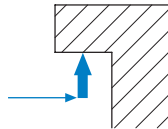
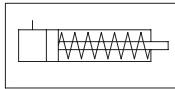

- The electric positioning unit moves the T-bolt clamp along the T-slot.
- A single-acting hydraulic cylinder generates the clamping force.
- Unclamping is effected by spring load with the operating pressure switched off.

Description

The electric positioning unit moves the T-bolt clamp by means of a chain. Hydraulic pressure is applied to the T-bolt clamp to generate the clamping force.

The hydraulic pressure must be maintained to secure the clamping force (e.g. with pilot controlled check valves). Therefore, pressure control by means of a pressure switch on the hydraulic power pack is necessary.

The electric positioning units may be switched off individually by the machine control so that these clamp units remain in their park position, where they are clamped.



Advantages

- Clamping of different die sizes
- Large clamping dimension tolerance
- Short clamping time
- Displacement path up to 1000 mm available
- Clamping in the park position possible
- All important functions electrically monitored
- High automation level
- Central operation

Accessories and fittings

- Pilot controlled check valves
- Screw joints
- Hydraulic hoses / hydraulic accessories
- Hydraulic power packs
- Limit switches / cable
- Plug connectors



Fixing is achieved with four hexagon head screws with flange (DIN 6921) M10x30, strength class 8.8 and two spring dowel pins Ø8x20(not included).

Technical Data

Positioning Unit	EVK		
Motor: Type	DC	alternatively	three-phase
Supply voltage	24V		400V 50 Hz
Motor power [W]	8		25
Positioning speed [mm/s]	150		145
Limit switches: Type	• Inductive proximity switches		
Switch voltage	• PNP normally open ; 10-30 V DC		
Designation			• Clamp unit in park position S1
			• Clamp unit at the die S2
			• End of displacement path (optional) S5
Plug connector	HAN 25 D HAN 6 E (additionally for three-phase drive)		
Clamp Unit	HKZ 104		
Clamping force [kN] / at operating pressure [bar]	104 / 400		
Max. loading force [kN] ¹⁾	130		
Max. operating pressure [bar]	400		
Clamping dimension tolerance [mm]	+/- 4		
Stroke [mm]	12		
Oil volume: Clamp [cm ³]	31		
Max. operating temperature [°C]	70		
Weight [kg]	20		

¹⁾ Mechanical damage may occur at higher load.

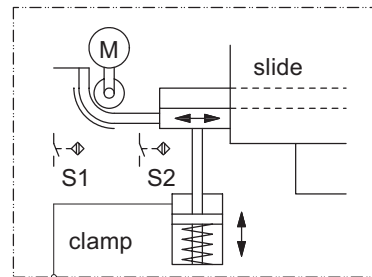
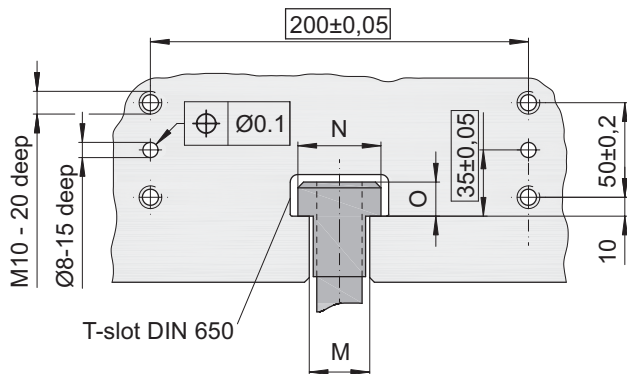
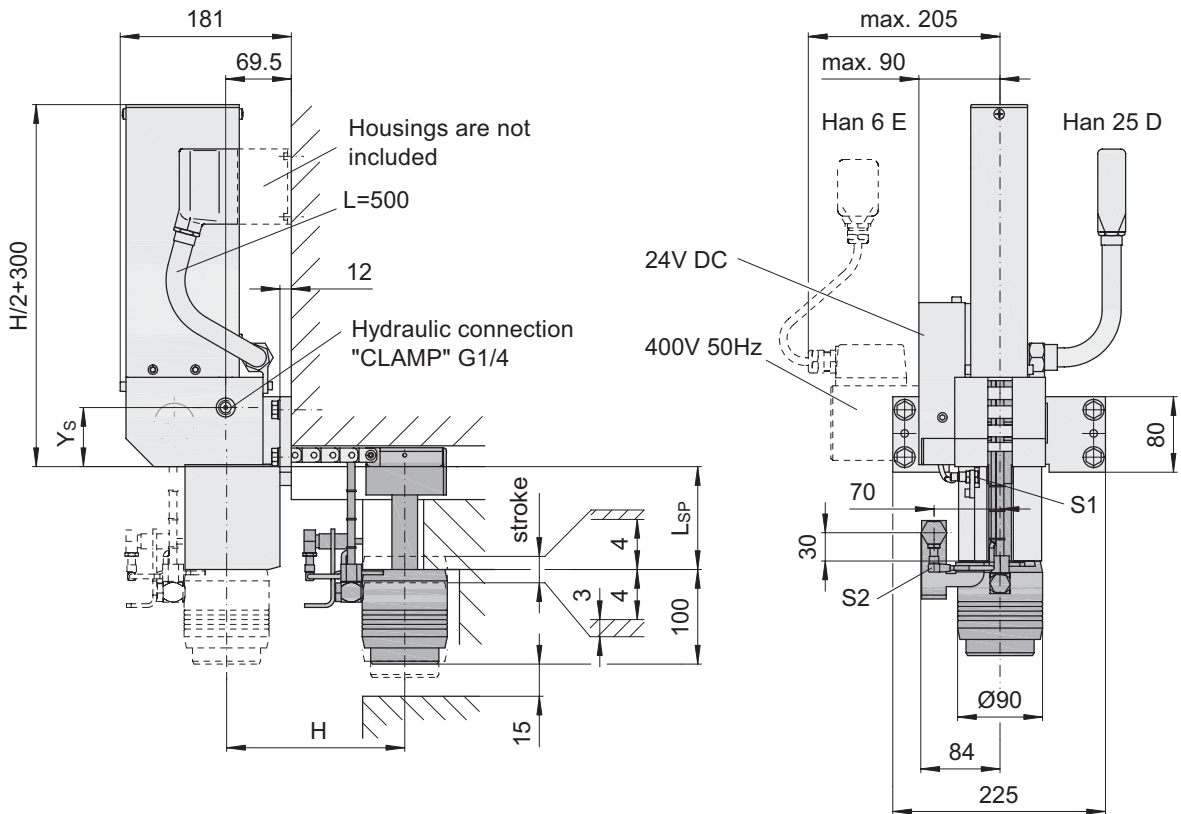

Example order

EVK - 400V 50 Hz - 700 - S5 - HKZ104 - 28 - 90

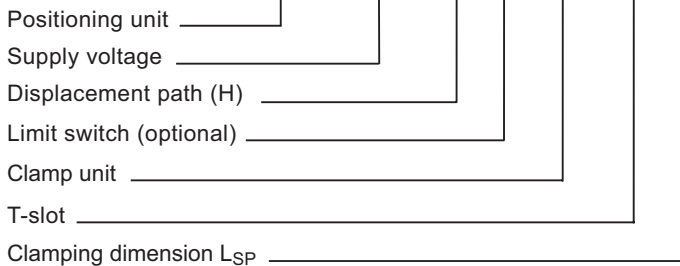

(Custom designs available on request)

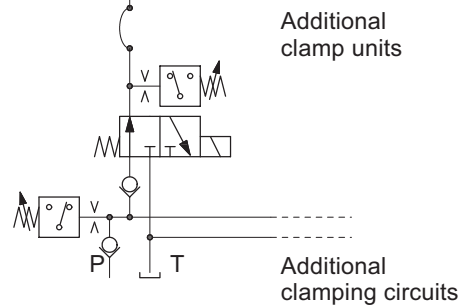

T-slot	M	N	O	Y _s
28	28	44	18	62,5
32	32	50	20	64,5
36	36	54	22	66,5